

Key Features:

- Ultra Wideband Output
- High Dynamic Range
- Tiny Frequency Step
- Harmonic Filtering
- Very low Phase Noise
- High RF Output Power
- USB COM Interface
- Industry Standard SCPI Commands
- OLED Display and control buttons
- Very Cost Effective
- Incredibly Compact
- Ultra-stable Frequency Reference
- Ethernet Control



SG PRO SERIES

LOW-NOISE MICROWAVE SIGNAL GENERATORS



Compact, Low Phase-Noise, Wideband

The SG-PRO Series devices are designed as a higher-performance version of the industry standard SG6000 line of compact and affordable USB RF signal generators. While remaining portable and low-cost, the PRO Series brings a powerful set of new features and upgrades:

- Wider frequency range (up to 40GHz)
- Harmonic filtering (-30dBc typical)
- Significantly lowered phase noise (6GHz: -95dBc@10KHz)
- Smaller frequency step size (2Hz)
- Optimized power level control resolution and range
- USB powered and controlled
- Simple Ethernet connectivity
- 10MHz internal and external reference source

Signal Generator Control

Unlike other signal generators in its class, the PRO series allows for stand-alone control AND PC USB remote control via a lightweight windows application or SCPI serial commands. Users can easily generate a microwave signal with no configuration or user manual needed. The stand-alone OLED display and interface buttons allow frequency selection, attenuator control, and RF output control without need for a host PC. All settings can be saved as boot-up defaults for added convenience.

SG PRO Applications

- Automated testing environments
- General RF lab use
- Production verification
- Educational / university lab use
- Aerospace / defense research
- Wireless infrastructure
- Line-of-sight links
- Up/Down-converting applications
- LTE Engineering
- Antenna design
- EMC Testing

DS Instruments



SG PRO SERIES

DEVICE FRONT AND REAR PANELS



SG6000PRO



SG12000PRO



SG22000PRO



SG30000PRO



SG40000PRO



SG PRO SERIES

MODEL COMPARISON MATRIX

	SG6000PRO	SG12000PRO	SG22000PRO	SG30000L	SG30000PRO	SG40000L	SG40000PRO
Min Frequency (MHz)	20	20	50	50	50	25000	100
Max Frequency (GHz)	7.0	13	23	30	30	40	40
10MHz External Reference Input	X	X	X	X	X	X	X
MCX Sweep Trigger Input					X		X
RFO Dynamic Range (dB) Step + Vernier	70	70	45	30	50	30	40
Harmonic Filtering	X	X	X		X	X	
Max Calibrated Power Output (dBm)	17	15	15	10	15	15	13
Ethernet + USB + Display	X	X	X	X	X	X	X
Frequency Step Size (Hz)	2	2	2	2	2	4	4
Ultra-stable Reference Clock					X		X

* The SG30000 has an additional dedicated datasheet

SG PRO SERIES

IN-DEPTH SYSTEM INFORMATION

Ease of Use

The SG PRO stand-alone panel controls, windows control GUI, and SCPI command set are all designed to be simple, intuitive, and complete.

Signal Generator USB Operation

With the SG PRO SERIES device connected to the PC via USB-C port, industry standard SCPI commands are used to fully control the instrument. The USB port is configured on the host PC as a virtual COM port. This feature allows users to control the PRO for automated test applications from many different operating systems and scripting languages and environments. Drivers for this virtual COM port are built-in to all modern and even most legacy operating systems including embedded and mobile platforms.

Precision Reference

All SG PRO devices have an ultra-low-noise 100MHz oscillator as the synthesized source reference. This is phase locked to a 10MHz internal ± 280 PPB TCXO or an external source for a combination of low-noise and temperature stability. The SG30000PRO and SG40000PRO models have an upgraded ± 10 PPB oven-controlled reference source.

Output Level Control

Power output level can be controlled via a internal step attenuator over a range of 30dB-60dB in 0.25dB or 0.5dB steps. An additional variable attenuator is also available for fine-tuning in smaller increments, typically referred to as *vernier* control.

Power Output Calibration

Power output is typically calibrated to ± 1.0 dB of the indicated level using multi-table lookup. The power vernier setting can be used to output more than the maximum if needed, this is referred to as *un-calibrated mode*.

Harmonic Filtering

The internal harmonic filtering matrix reduces harmonics to 25dB below the standard PLL output levels. Typically -30 to -35dBc for the second and third harmonics.

Optional Ethernet Control

The same SCPI USB commands can be sent to the optional Ethernet port for remote test environments where a host system is located at a distance.

System Memory Boot Defaults

All user-configured settings like frequency and power can be saved to the device non-volatile memory so that after a reboot, or moving the device from a PC host to a USB battery pack or wall adapter, it can be powered on with the previous settings loaded automatically.

SG PRO SERIES

Case Dimensions

SG6000PRO

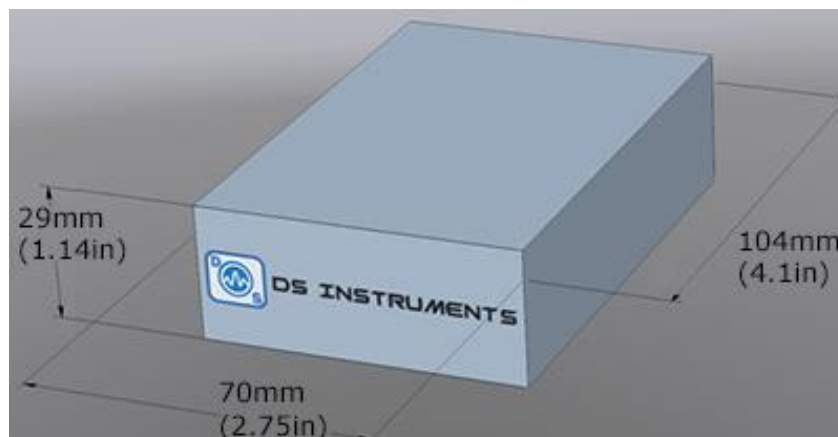

SG12000PRO
SG22000PRO
SG30000L

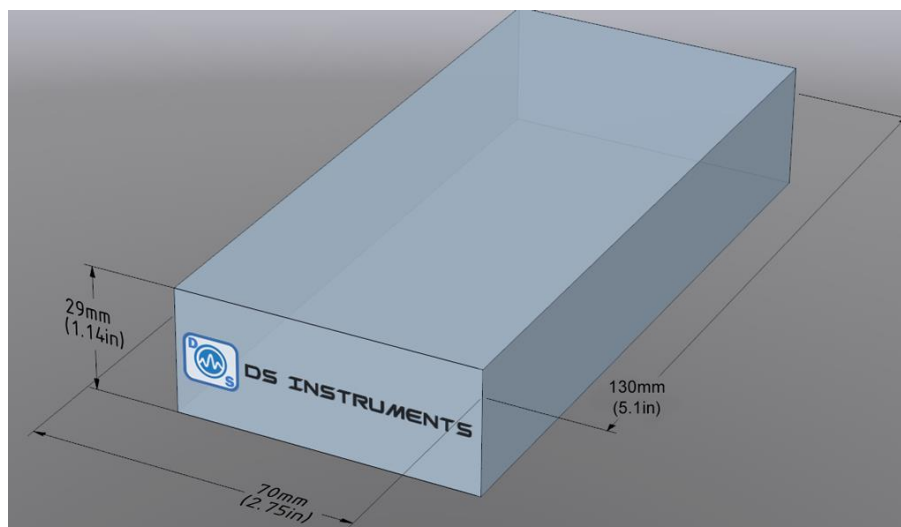

SG30000PRO
SG40000PRO

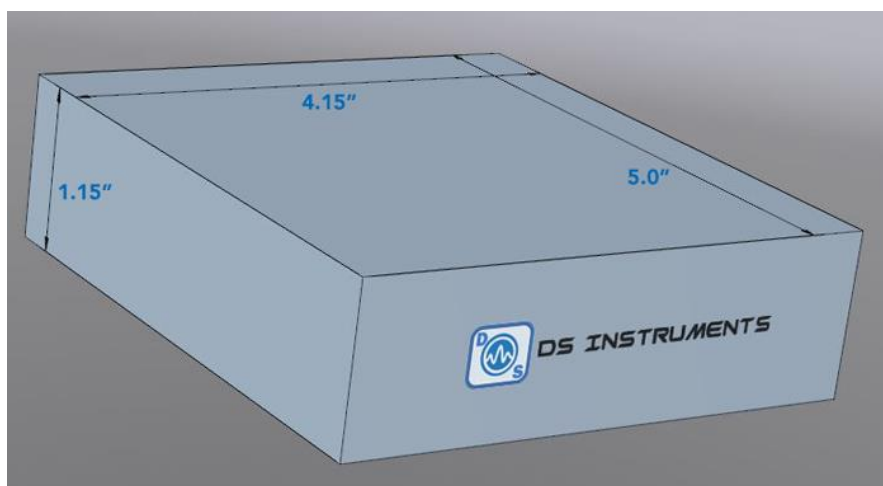

SG PRO SERIES

Typical User Connections via USB

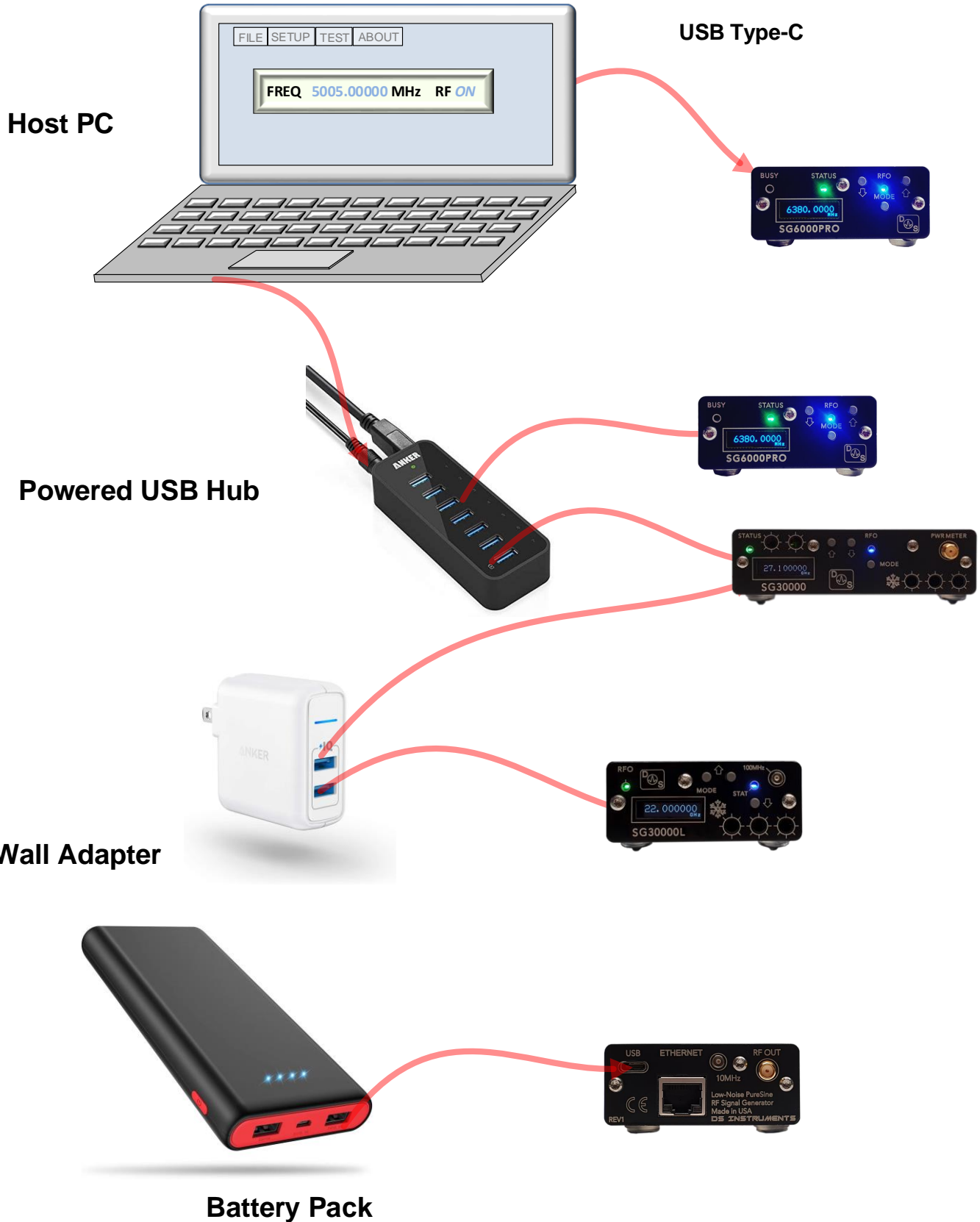

SG PRO SERIES

SPECIFICATIONS

Conditions: 25° C, Internal ultra-low phase noise oscillator free running

Parameter	Min	Max	Typ	Units
Output Frequency Range	0.02	7, 13, 23		GHz
Output Power Max (Calibrated)			+15	dBm
Uncalibrated (Typical)			+17	dBm
Phase Noise (10KHz Offset)				
@ 6.0GHz			-95	dBc
@ 12GHz			-94	dBc
@ 18GHz			-90	dBc
Output Port Return Loss	8		12	dB
Freq Step Size			2	Hz
RF Attenuator Step Size (SG6000PRO)			0.25	dB
(SG12000PRO, SG22000PRO, SG30000)			0.50	dB
Step Attenuator Range (< 6.0GHz)		60.0		dB
(6.0 – 23GHz)		31.0		dB
Typical power calibration accuracy	±2.5		±1.0	dB
Power Vernier Range (variable attenuator)	0	15		dB
Typical Vernier Minimum Increment		.15	0.05	dB
Typical frequency lock and settle time		5	3	mS
Reference Oscillator Stability (100MHz XO Unlocked)			±16	PPM
10MHz Internal Source Stability (TCXO)			±280	PPB
Reference input power level	-10	+10	0	dBm
Device Temperature Range	-20	55	25	C
USB voltage input	4.6	5.4	5.0	Vdc
USB current requirement		1.75	0.75	A
Oscillator warm up time	-40	20	10	Min
Harmonic levels (Filtered Bands)		-28	-30	dBc
(Unfiltered Bands)			-12	dBc

SG PRO SERIES

Windows Control GUI Application

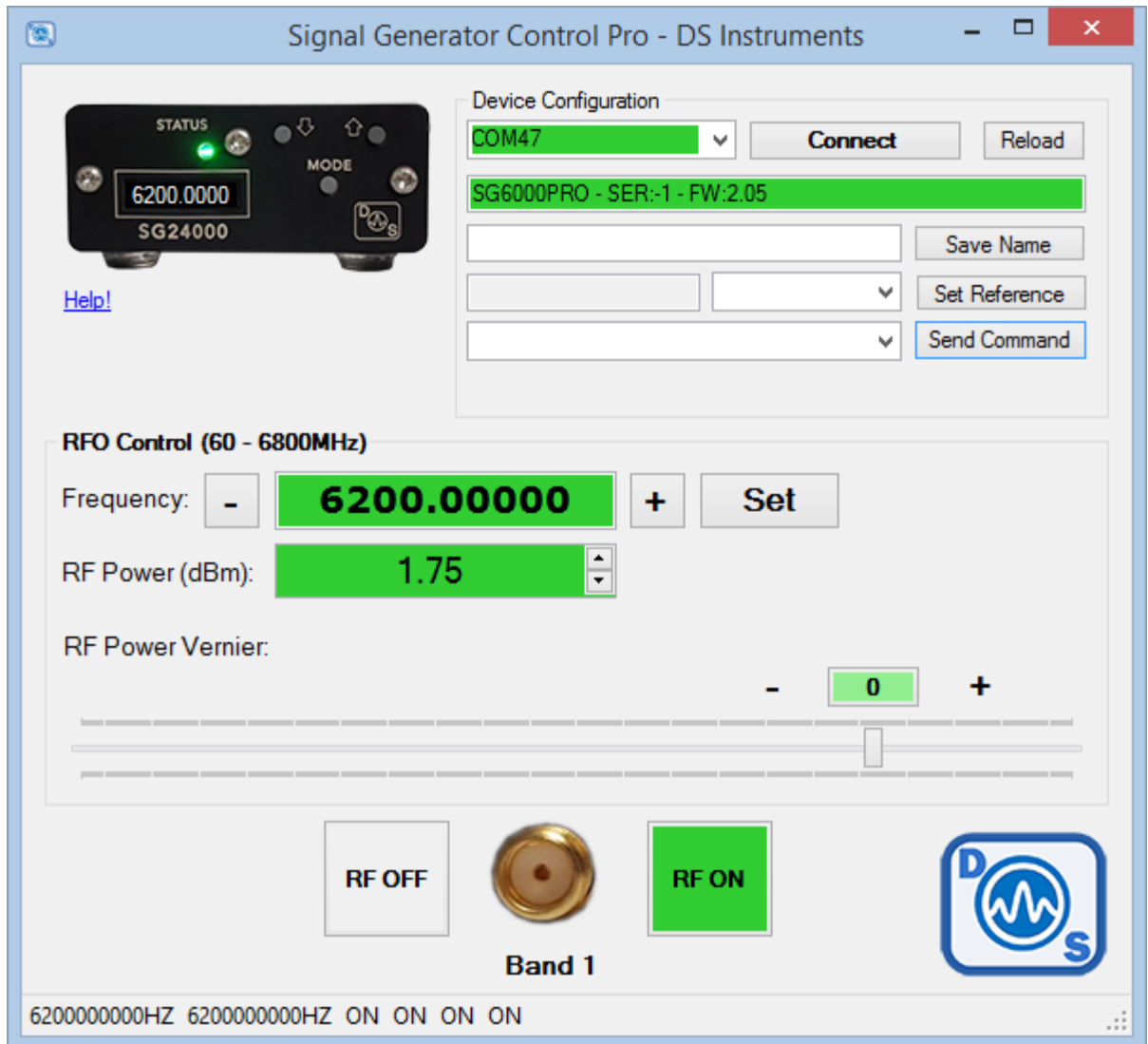

Our easy-to-use control software requires no installation or drivers, just Microsoft .NET framework. This software searches all COM ports and the local network for compatible devices.

The “Save Name” button can be used to save an inventory tag or nickname to the device’s non-volatile memory.

Most devices will auto-detect the appropriate clock reference source, but the “Set Reference” button can also be used to force the use of an external clock if needed.

The “Send Command” dropdown menu provides some advanced commands like “*SAVSTATE” that will save all the current settings as boot-up defaults, and the “SYST:ERR?” command that will return any pending errors.

Download Link: <https://www.ds instruments.com/downloads/>

SG PRO SERIES

Windows Control GUI Application - Ethernet

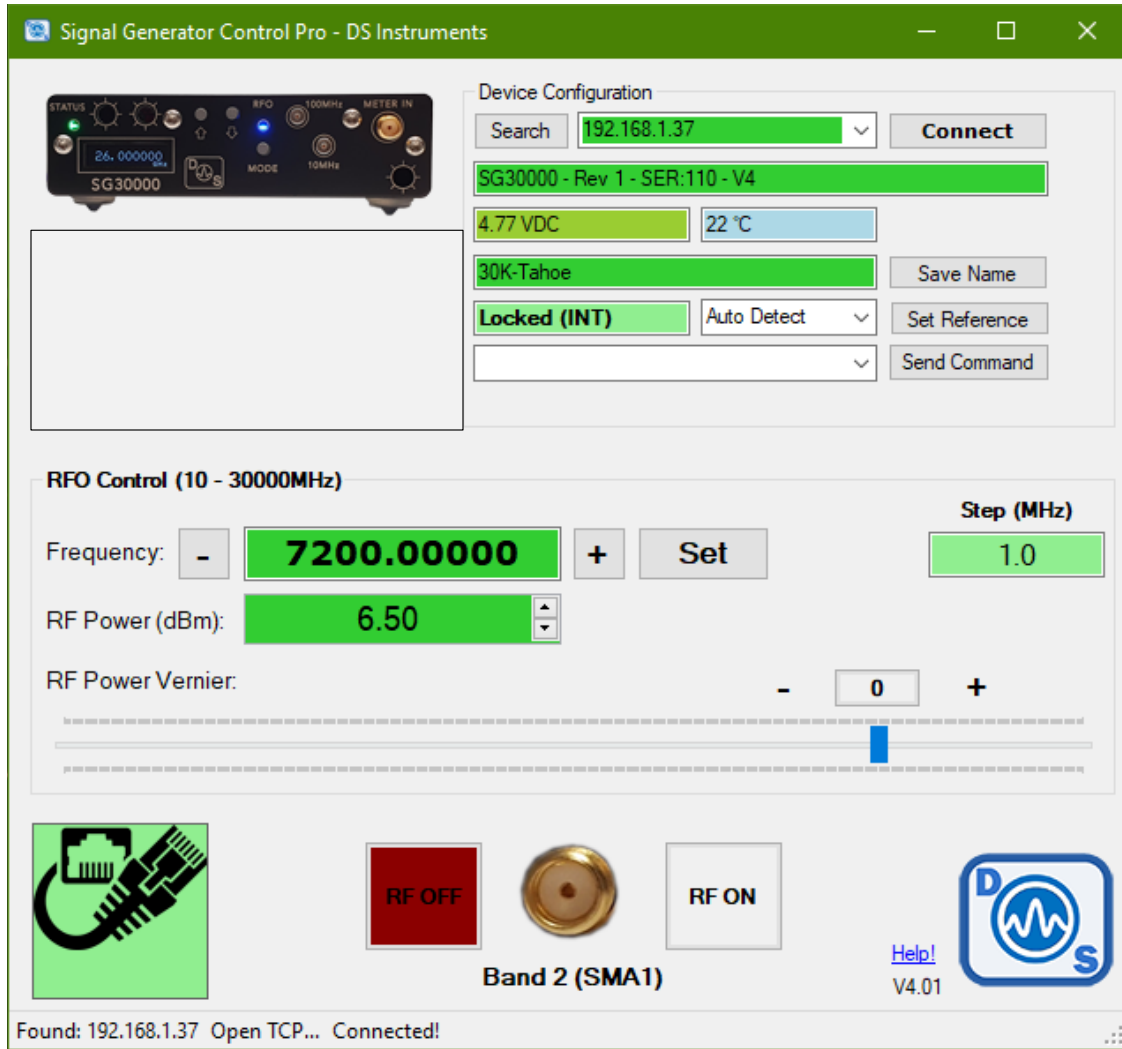

Our instruments ship with DHCP enabled by default, STATIC IP is supported, and can be configured via the web interface using a standard internet browser.

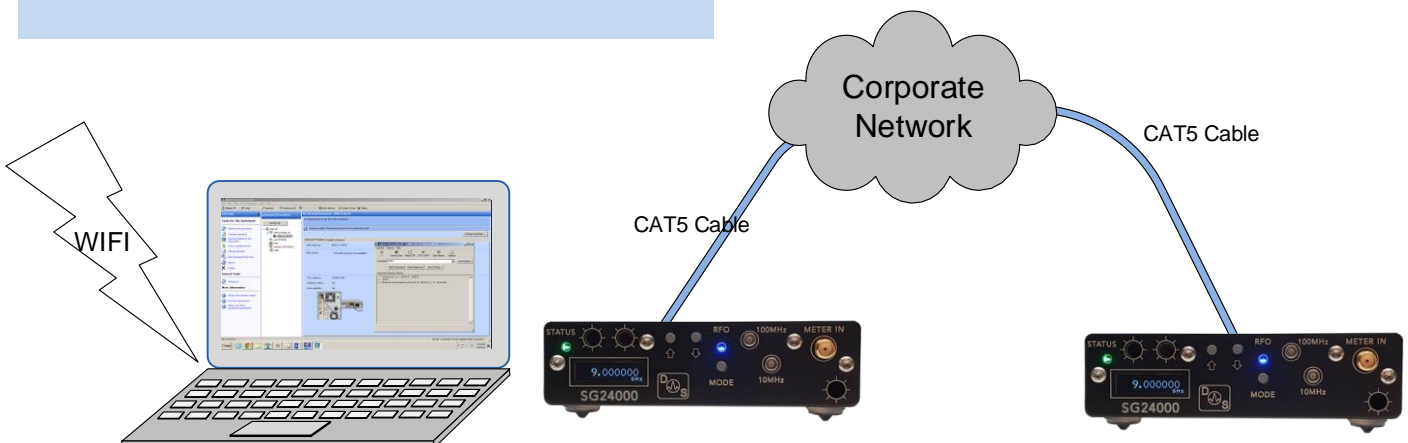

SG PRO SERIES

Power Output and Calibration



DS Instruments signal generators are each calibrated at the factory to have accurate power output levels across the device bandwidth. When the VERNIER setting is at the default of ZERO, the device is operating in calibrated mode with no adjustment to the power setting shown.

If the fine power tune slider is moved in the control software, or the Vernier setting is changed from the front panel, the output is more (positive), or less (negative), than the dBm value shown. We now consider the device to be operating in uncalibrated mode. This mode will be indicated by the power level box changing colors in the control software.

Say you are at +10dBm, and need more power, slide the Vernier bar to the right. This is called uncalibrated mode because there is no feedback from the amplifiers to let the device know the exact power level at the current frequency. You would need a power meter to know the actual output in uncalibrated mode.

Typically this is used to get more than the max calibrated level, or to fine tune between digital attenuator steps. It can also be used to get a lower power than the minimum calibrated level by about 10dB.

Uncalibrated mode can usually achieve 3-5dB more power than the max level stated, depending on frequency.

The Vernier power resolution is typically around 0.05dB.

SG PRO SERIES

Windows Sweeping Control GUI Application

DSI signal generators support two sweeping **system modes**: SCAN, and LIST. Scan mode generates an evenly spaced set of points between two user defined frequencies. List mode lets the user enter an arbitrary list of points to sweep through.

Mode: Single or Continuous: will the sweep execute once only, or sweep repeat forever.

Direction: Up, Down: Down will initiate the sweep from the stop frequency downward.

Points: Total number of frequency points including start and stop (not used in LIST mode)

Dwell: Number of milliseconds to wait at each frequency point

Start: Bottom frequency point to start at when in UP direction (not used in LIST mode)

Stop: Top frequency point to end at in UP direction (not used in LIST mode)

Save: Load all these sweep settings into the device for the next trigger

Scan mode sweeping parameters can be saved to non-volatile device memory so that no host system is required to sweep after a system reset. This is convenient for when taking a device into the field, or when changing the power source frequently. Sending the command “*SAVESTATE” once the sweep is saved and configured will put it into NVM memory.

SG PRO SERIES

SCPI COM Port Connection

All of our products can be controlled from any serial-capable programming language or environment. No extra drivers are required. MATLAB, .NET, Linux, python are all popular. We use Visual Studio 2019 and C# for our standard GUI. First determine the port number that your device has installed itself as:

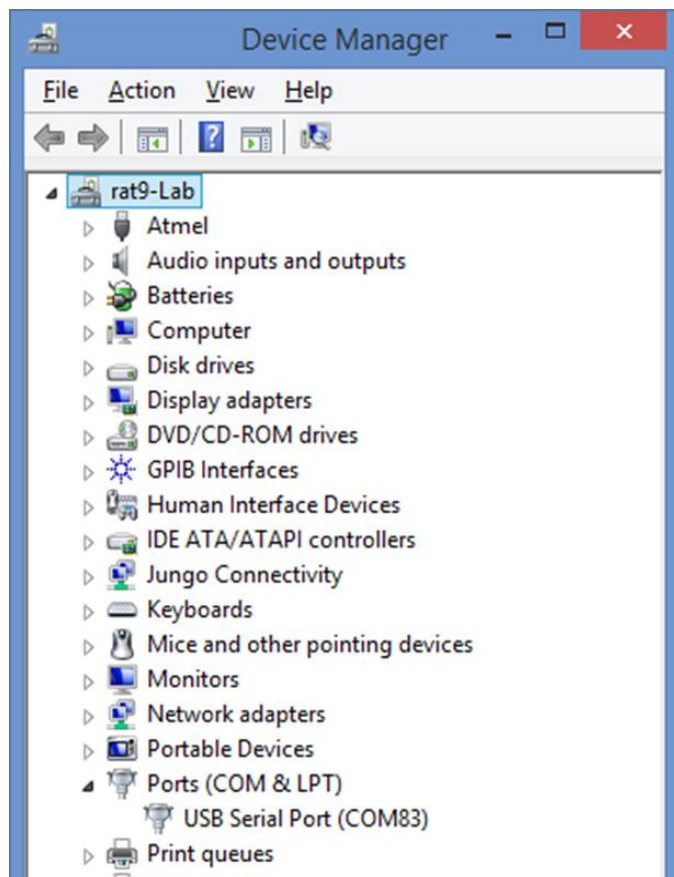

Command terminator is LINEFEED ("\n")

COM Port Settings:
115200bps, 8bits, 1 stop, no parity, no flow control

Example Code (C# .NET Framework):

```
using System;
using System.IO.Ports;    // include serial port library

SerialPort myPort = new SerialPort("COM83", 115200, System.IO.Ports.Parity.None, 8, System.IO.Ports.StopBits.One);
myPort.Open();           // open the port we just made
myPort.WriteLine("*IDN?"); // send any command here
myPort.ReadTimeout = 250;

string myResponse = myPort.ReadLine(); // read back the response
System.Threading.Thread.Sleep(30);     // delay before sending the next command
```

SG PRO SERIES

SCPI COM Common Commands

FREQ:CW 4.55GHz	Set output Frequency
FREQ:CW?	Return current Frequency
OUTP:STAT	Turn on or off the RF output
OUTP:STAT?	Return if output is enabled
POWER 5.0	Set output RF level in dBm
POWER?	Return current attenuation value
VERNIER 0.6	Set the output power level vernier (fine tune variable attenuator)
VERNIER?	Return vernier setting
*IDN?	Return the SCPI identification string
*UNITNAME ted	Set a unique name in flash memory
*UNITNAME?	Return this device's name
SYST:ERR?	Returns any pending error messages
SYST:DBG?	Returns last status message
*RST	Reset unit now
*DISPLAY OFF	Power ON or OFF the display
*BUZZER OFF	Mute the buzzer
*SAVESTATE	Save frequency & attenuation as boot defaults
SWE:MODE LIST	Select the mode for sweeping (LIST, SCAN)
SWE:DWELL 100	Sweep dwell time in milliseconds
LIST:DIR DOWN	Sweep direction
INIT:IMM	Start the sweep now
INIT:CONT	Sweep continuous mode or single
ABORT	Stop the sweep now
SWE:ACTIVE?	Is the device sweeping now
FREQ:START 9GHZ	Sweep start frequency
FREQ:STOP 10GHZ	Sweep stop frequency
SWE:POINTS 10	Sweep point count
LIST:ADD 11GHZ	Add a point to the end of the sweeping list
LIST:CLEAR	Clear the working frequency list and start over

SG PRO SERIES

Front Panel Device Control



The MODE button determined what property the up and down buttons modify. The default upon power up is frequency in large steps.

Mode State Diagram

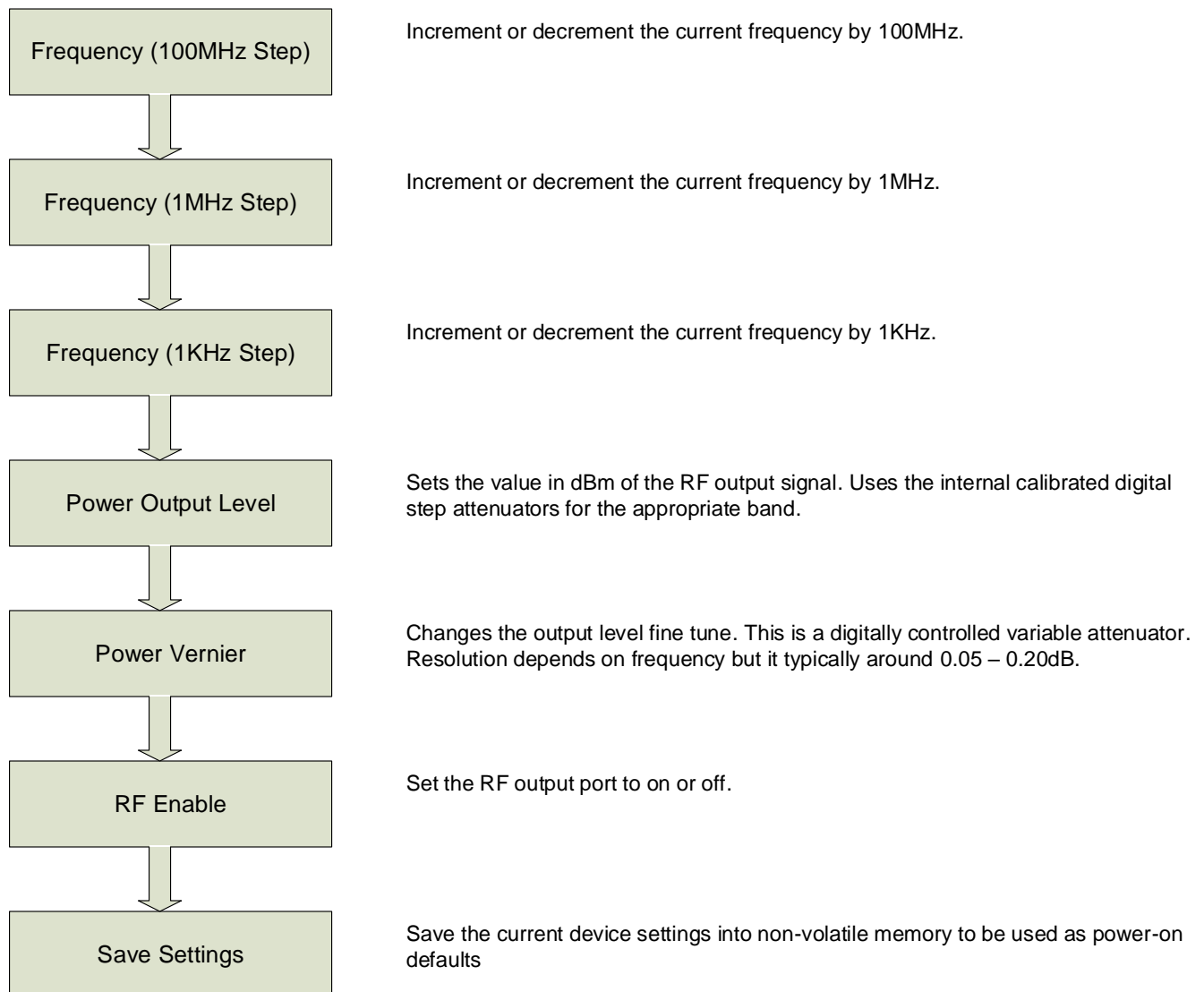

SG PRO SERIES

HARMONICS

The **SG6000PRO**, **SG12000PRO**, and **SG30000PRO** focus on filtering the harmonics inherent to PLL based synthesizers. All three are equipped with filter matrices similar to the block diagram shown below.

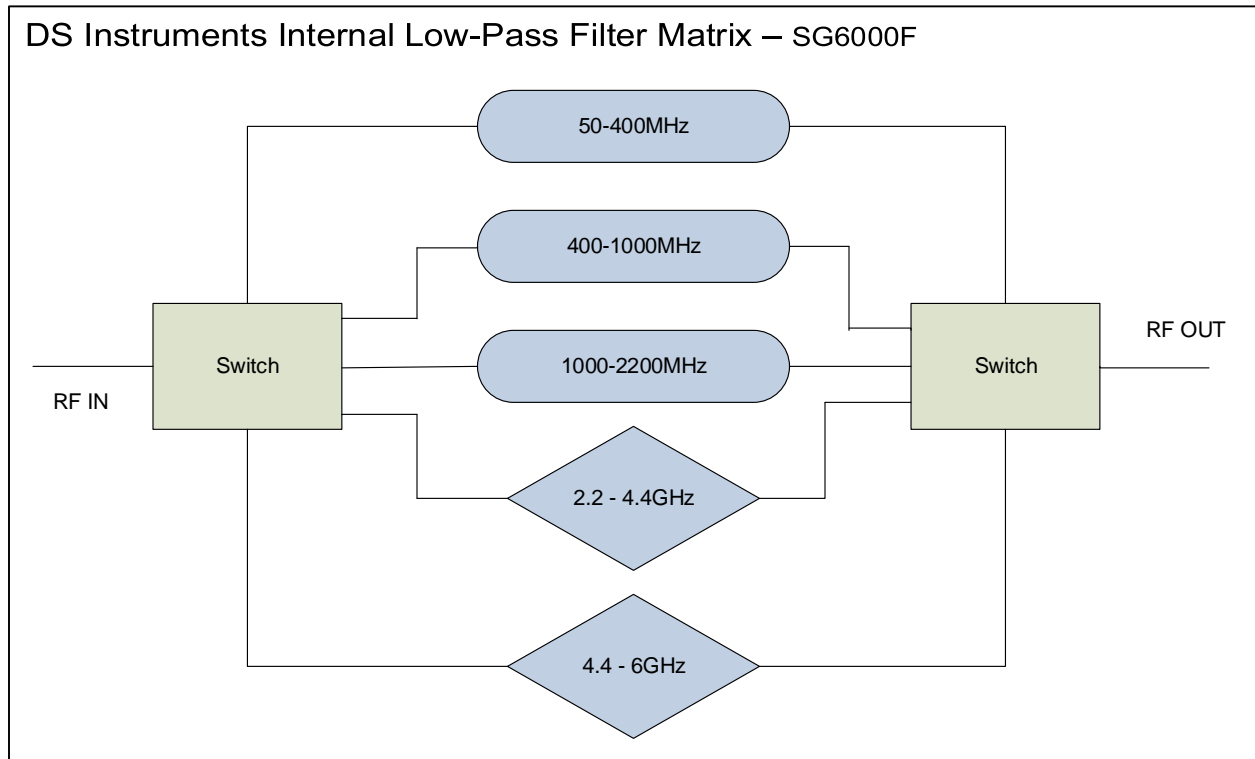

Harmonics are more plentiful at low frequencies (<500MHz) in wideband systems, causing more pronounced distortion. Our filtering is typically able to reduce the second harmonic to -30dBc, and the third harmonic to under -40dBc. Unfiltered synthesizers can have harmonics as high as -10dBc extending well beyond the 9th.

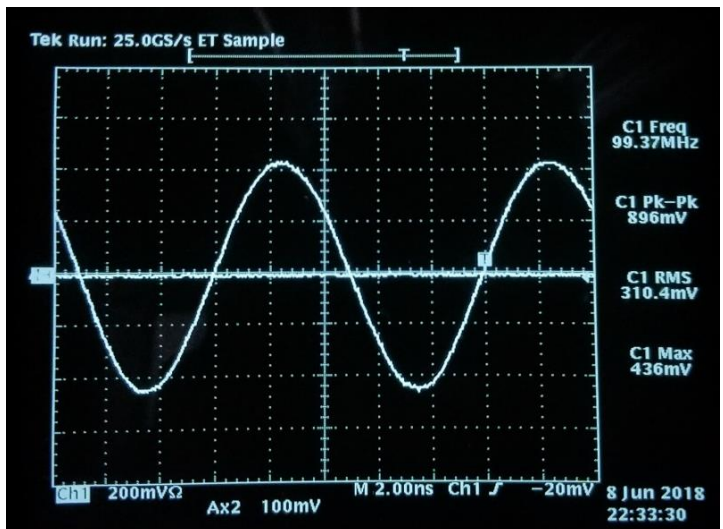
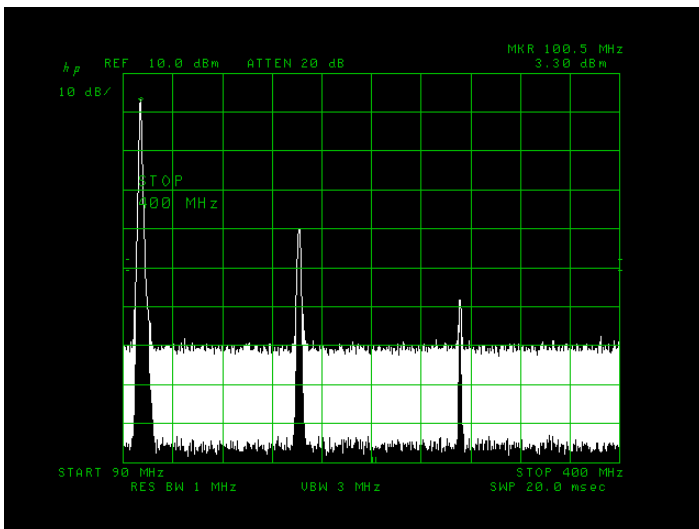

SG PRO SERIES

Typical Phase Noise (SG6000PRO, SG12000PRO)

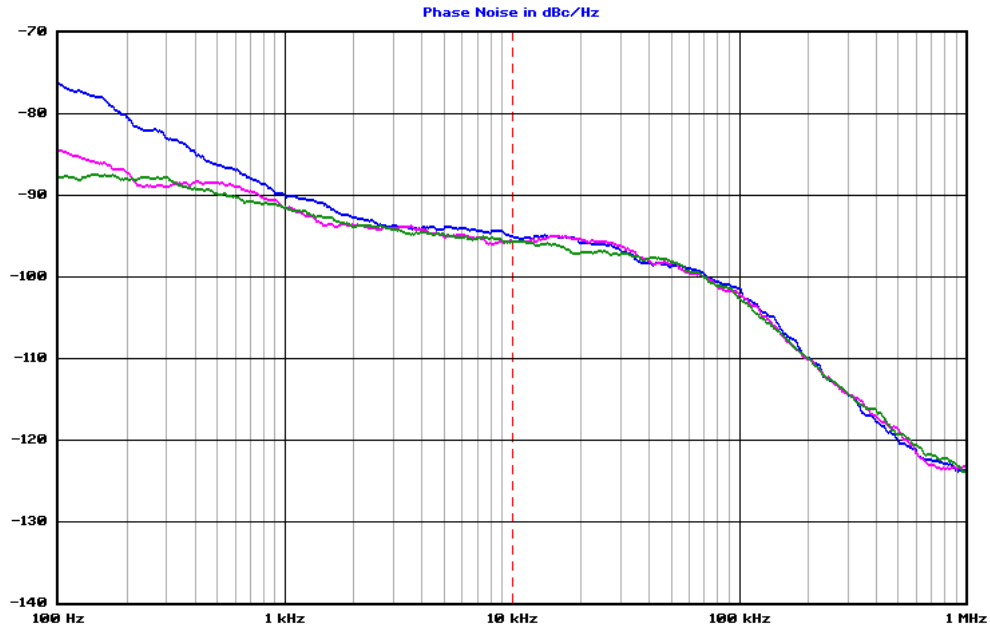

Trace	Carrier Hz	Carrier dBm	dBc/Hz at 10000 Hz	RF Atten dB
PRO-R4-Ext10	6 000 000 000	8.00	-95.0	10
PRO-R4-Int10	5 999 999 990	8.00	-95.6	10
PRO-R4-free100	5 999 998 750	8.00	-95.6	10

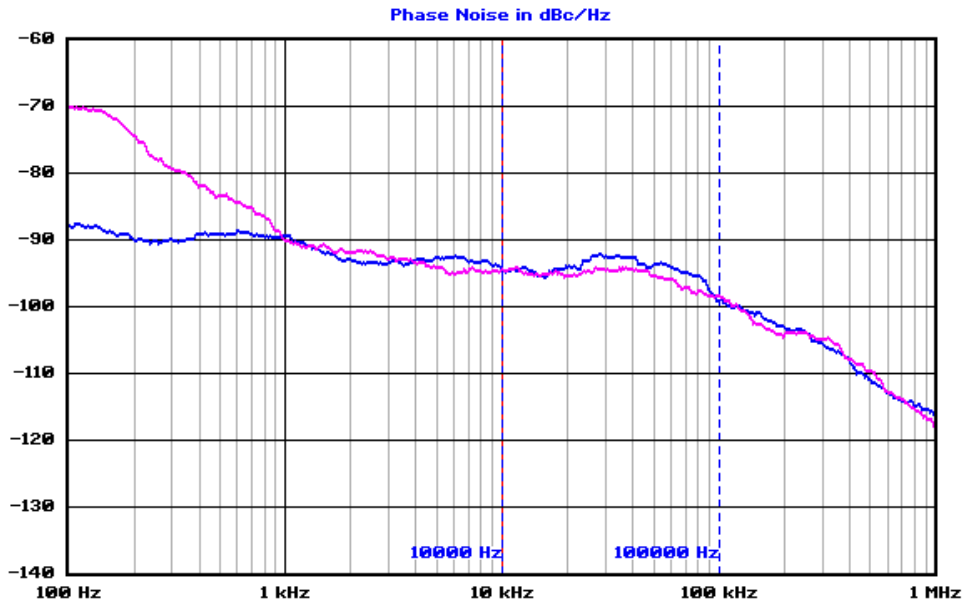

Trace	Carrier Hz	dBc/Hz at 10000 Hz	RMS Jitter
SC12000PRO-free	11 999 990 000	-94.6	1.1E-013 s
SC12000PRO-lockedExt	12 000 000 000	-94.4	9.1E-014 s

SG PRO SERIES

Typical Phase Noise (SG22000PRO)

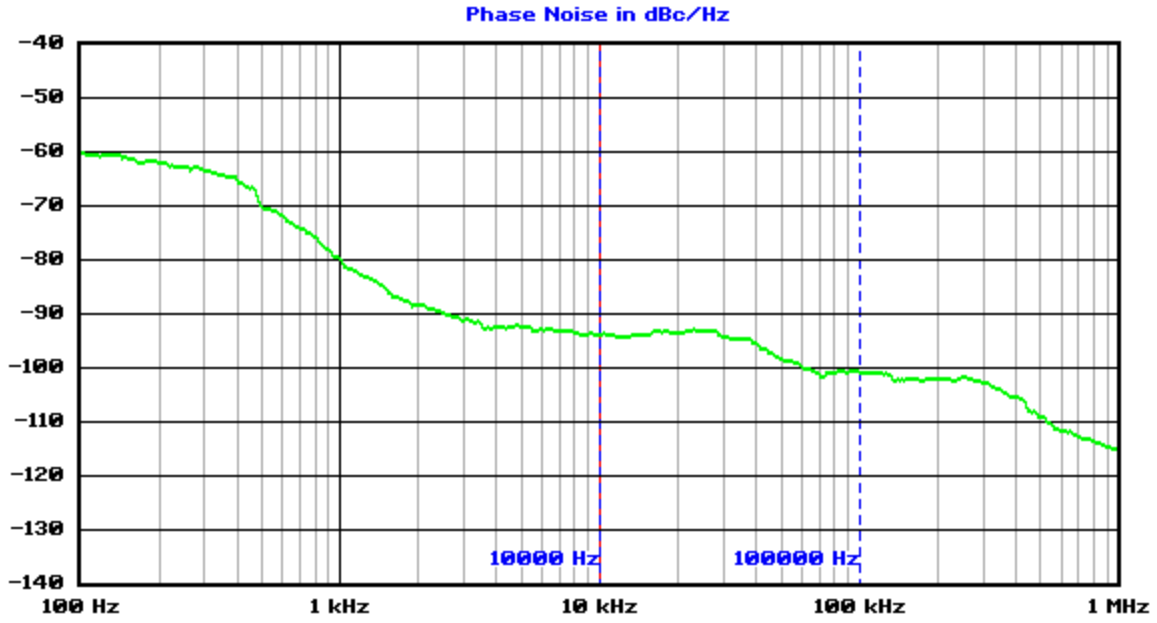

Trace	Carrier Hz	dBc/Hz at 10000 Hz	RMS Jitter
SG30000	18 000 000 000	-93.6	5.5E-014 s

SG PRO SERIES

CW Output Plots

